

# PARTS, OPERATION AND MAINTENANCE MANUAL for MANUAL CHAIN HOIST MODELS

**MCH5-005**

1/2 ton

**MCH5-010**

1 ton

**MCH5-015**

1-1/2 ton

**MCH5-020**

2 ton

**MCH5-030**

3 ton

**MCH5-050**

5 ton

Unless otherwise noted, tons in this manual are metric tons (2,200 lbs.)

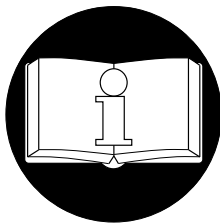
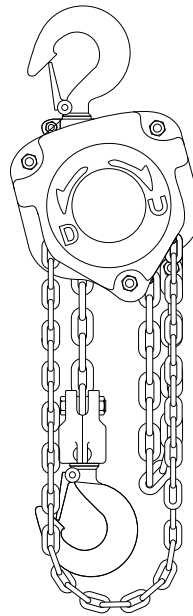
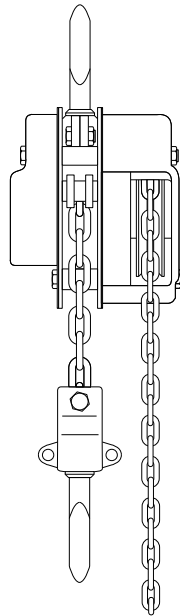

**READ THIS MANUAL BEFORE USING THESE PRODUCTS.** This manual contains important safety, installation, operation and maintenance information. Make this manual available to all persons responsible for the operation, installation and maintenance of these products.

## **⚠ WARNING**

**Do not use this hoist for lifting, supporting, or transporting people or lifting or supporting loads over people.**

**Always operate, inspect and maintain this hoist in accordance with American National Standards Institute Safety Code (ASME B30.16) and any other applicable safety codes and regulations.**

**Refer all communications to the nearest Ingersoll-Rand Material Handling Office or Distributor.**

Form MHD56028  
Edition 7  
October 1996  
71049530  
© 1996 Ingersoll-Rand Company

**INGERSOLL-RAND**  
**MATERIAL HANDLING**

## SAFETY INFORMATION

This manual provides important information for all personnel involved with the safe installation, operation and proper maintenance of this product. Even if you feel you are familiar with this or similar equipment, you should read this manual before operating the product.

### Danger, Warning, Caution and Notice

Throughout this manual there are steps and procedures which, if not followed, may result in an injury. The following signal words are used to identify the level of potential hazard.

#### DANGER

Danger is used to indicate the presence of a hazard which *will* cause *severe* injury, death, or substantial property damage if the warning is ignored.

#### WARNING

Warning is used to indicate the presence of a hazard which *can* cause *severe* injury, death, or substantial property damage if the warning is ignored.

#### CAUTION

Caution is used to indicate the presence of a hazard which *will* or *can* cause *minor* injury or property damage if the warning is ignored.

#### NOTICE

Notice is used to notify people of installation, operation, or maintenance information which is important but not hazard-related.

### Safety Summary

#### WARNING

- Do not use this hoist for lifting, supporting, or transporting people or lifting or supporting loads over people.
- Hoists are designed to provide a 4 to 1 safety factor. The supporting structures and load-attaching devices used in conjunction with this hoist must provide adequate support to handle all hoist operations plus the weight of the hoist and attached equipment. This is the customer's responsibility. If in doubt, consult a registered structural engineer.

The National Safety Council, Accident Prevention Manual for Industrial Operations, Eighth Edition and other recognized safety sources make a common point: Employees who work near cranes or assist in hooking on or arranging a load should be instructed to keep out from under the load. From a safety standpoint, one factor is paramount: conduct all lifting operations in such a manner that if there were an equipment failure, no personnel would be injured. This means keep out from under a raised load and keep out of the line of force of any load.

**Ingersoll-Rand** Material Handling hoists are manufactured in accordance with the latest ASME B30.16 standards.

The Occupational Safety and Health Act of 1970, generally places the burden of compliance with the user, not the manufacturer. Many OSHA requirements are not concerned or connected with the manufactured product but are, rather, connected with the final installation. It is the owner's and user's responsibility to determine the suitability of a product for any particular use. It is recommended that all applicable industry, trade association, federal, state and local regulations be checked. Read all operating instructions and warnings before operation.

**Rigging:** It is the responsibility of the operator to exercise caution, use common sense and be familiar with proper rigging techniques. Refer to ASME B30.9 for rigging information, American National Standards Institute, 1430 Broadway, New York, NY 10018.

#### NOTICE

- Using other than genuine Ingersoll-Rand Material Handling parts will void the warranty.

## SAFE OPERATING INSTRUCTIONS

The following warnings and operating instructions have been adapted in part from American National (Safety) Standard ASME B30.16 (Overhead Hoists) and are intended to avoid unsafe operating practices which might lead to injury or property damage.

**Ingersoll-Rand** recognizes that most companies who use hoists have a safety program in force in their plants. In the event you are aware that some conflict exists between a rule set forth in this publication and a similar rule already set by an individual company, the more stringent of the two should take precedence.

Safe Operating Instructions are provided to make an operator aware of dangerous practices to avoid and are not necessarily limited to the following list. Refer to specific sections in the manual for additional safety information.

1. Only allow personnel, trained in safety and operation of this product, to operate the hoist.
2. Only operate a hoist if you are physically fit to do so.
3. When a "DO NOT OPERATE" sign is placed on the hoist, do not operate the hoist until the sign has been removed by designated personnel.
4. Before each shift, the operator should inspect the hoist for wear or damage.
5. Never use a hoist which inspection indicates is worn or damaged.

6. Periodically, inspect the hoist thoroughly and replace worn or damaged parts.
7. Lubricate the hoist regularly.
8. Do not use hoist if hook latch has been sprung or broken.
9. Check that the hook latches are engaged before using.
10. Never splice a hoist chain by inserting a bolt between links.
11. Only lift loads less than or equal to the rated capacity of the hoist. Refer to "SPECIFICATION" section.
12. When using two hoists to suspend one load, select two hoists each having a rated capacity equal to or more than the load. This provides adequate safety in the event of a sudden load shift.
13. Never place your hand inside the throat area of a hook.
14. Never use the hoist load chain as a sling.
15. Never operate a hoist when the load is not centered under the hook. Do not "side pull" or "yard."
16. Never operate a hoist with twisted, kinked, "capsized" or damaged load chain.
17. Do not force a chain or hook into place by hammering.
18. Never insert the point of the hook into a chain link.
19. Be certain the load is properly seated in the saddle of the hook and the hook latch is engaged.
20. Do not support the load on the tip of the hook.
21. Never run the load chain over a sharp edge. Use a sheave.
22. Pay attention to the load at all times when operating the hoist.
23. Always ensure that you, and all other people, are clear of the path of the load. Do not lift a load over people.
24. Never use the hoist for lifting or lowering people, and never allow anyone to stand on a suspended load.
25. Ease the slack out of the chain and sling when starting a lift. Do not jerk the load.
26. Do not swing a suspended load.
27. Do not leave a load suspended when the hoist is unattended or not in use.
28. Never weld or cut on a load suspended by the hoist.
29. Never use the hoist chain as a welding electrode.
30. Do not operate hoist if chain jumping, excessive noise, jamming, overloading, or binding occurs.
31. Only operate the hoist with manual power.
32. After use, or when in a non-operational mode, the hoist should be secured against unauthorized and unwarranted use.

## SPECIFICATIONS

### Model Code Explanation

Model Code Example

MCH5 - 050 - 10 - 8

Series: **MCH5** \_\_\_\_\_

Hoist Capacity: \_\_\_\_\_

- 005 = 1/2 metric ton (1,100 lbs.)
- 010 = 1 metric ton (2,200 lbs.)
- 015 = 1-1/2 metric ton (3,300 lbs.)
- 020 = 2 metric ton (4,400 lbs.)
- 030 = 3 metric ton (6,600 lbs.)
- 050 = 5 metric ton (11,000 lbs.)**

Lift (Hoist load chain/hook travel): \_\_\_\_\_

- 10 = 10 feet (3 m) (standard)**
- 15 = 15 feet (5 m)
- 20 = 20 feet. (6 m)
- XX = Specify length
- F = Hoist without load chain

Hand Chain (Hand chain is 2 ft. less than lift): \_\_\_\_\_

- 8 = 8 ft. (10 foot lift minus 2 feet - standard)**
- 13 = 10 ft. (15 foot lift minus 2 feet)
- 18 = 18 ft. (20 foot lift minus 2 feet)
- XX = Specify length

**Table 1**

Model No.	Rated Capacity metric tons*	Pull to lift rated load		Chain size (mm)	Chain Overhauled to lift load 1 ft (0.3 m)		No. of chain falls	Net Weight (std. 10 ft. lift)	
		lb	kg		ft	m		lb	kg
MCH5-005	1/2	59	27	5.0	25	7.6	1	19	8.6
MCH5-010	1	76	34	6.3	39	11.9	1	25	11.5
MCH5-015	1-1/2	78	35	7.1	58	17.7	1	30	13.8
MCH5-020	2	80	36	8.0	75	22.9	1	48	22
MCH5-030	3	81	37	7.1	116	35.4	2	49	22
MCH5-050	5	89	40	9.0	187	57.0	2	90	41

\* One metric ton = 2,200 lbs.

## WARNING TAG

Each hoist is supplied from the factory with the safety tag shown. If the tag is not attached to your unit, order a new tag and install it. Refer to the parts list for the part number. Read and obey all warnings and other safety information attached to this hoist. Tag may be shown smaller than actual size.

**⚠ WARNING**

**Failure to follow these warnings may result in death, severe injury or property damage:**

- Do not operate this hoist before reading operation and maintenance manual. 
- Do not lift more than rated load.
- Do not lift people or loads over people.
- Do not operate hoist with twisted, kinked or damaged chain.
- Do not operate a damaged or malfunctioning hoist.
- Do not operate when chain cannot form straight line with load.
- Do not operate hoist with other than manual power.
- Do not remove or obscure warning labels.

Read the latest edition of ASME B30.16.  
Comply with other federal, state and local rules.  
P/N 71038863C  
for manual chain hoists

**INGERSOLL-RAND**  
MATERIAL HANDLING®

## INSTALLATION

Prior to installing the hoist, carefully inspect it for possible shipping damage. Hoists are supplied fully lubricated from the factory. Lubrication of the load chain is recommended before initial hoist operation.

### ⚠ CAUTION

• Owners and users are advised to examine specific, local or other regulations, including American National Standards Institute and/or OSHA Regulations which may apply to a particular type of use of this product before installing or putting hoist to use.

### ⚠ WARNING

• A falling load can cause injury or death. Before installing, read "SAFETY INFORMATION".

• Depending on the model selected, the hoist may weigh more than 90 lbs. (41 kg). If parts of the hoist are dropped, they can cause injury, death or property damage. Adequately support the hoist during installation.

Hoists are designed to provide a 4 to 1 safety factor. The supporting structures and load-attaching devices used in conjunction with this hoist must provide adequate support to handle all hoist operations plus the weight of the hoist and attached equipment. This is the customer's responsibility. If in doubt, consult a registered structural engineer.

The MCH5 manual chain hoist must be used in a vertical position to provide a straight line pull from top hook to bottom hook. The hoist must be positioned so that it does not contact the support members when in use. When operating in limited areas suitable lifting attachments or slings must be used to prevent the hoist body and hand chain from being obstructed.

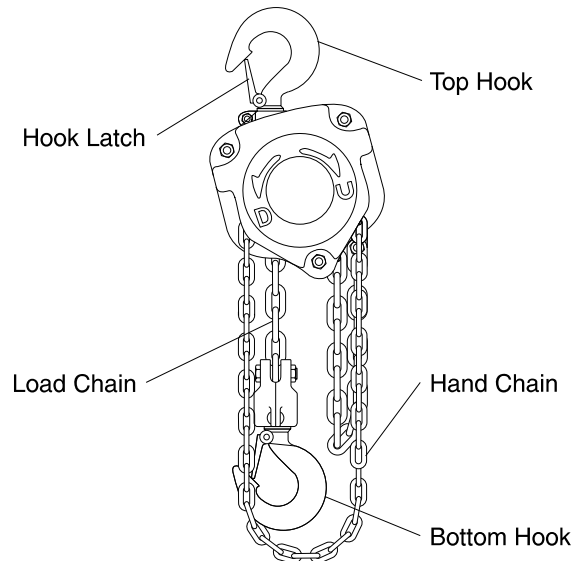

(Dwg. MHP0442)

## Initial Operating Checks

Operate the hoist with a test load (10% of rated capacity) by raising and lowering this load several times. Verify the brake operation by lowering the same load to check load does not slip when lowering stops.

### NOTICE

- **Each time a load is lifted, the operation of the brake should be checked by raising the load slightly and stopping to ensure the brake will hold the load before proceeding to lift the load.**

## OPERATION

The four most important aspects of hoist operation are:

1. Follow all safety instructions when operating the hoist.
2. Allow only people trained in safety and operation of this hoist to operate the hoist.
3. Subject each hoist to a regular inspection and maintenance procedure.
4. Be aware of the hoist capacity and weight of load at all times.

### ⚠ WARNING

- **Only allow personnel trained in safety and operation of this hoist to operate the hoist.**
- **The hoist is not designed or suitable for lifting, lowering or moving persons. Never lift loads over people.**

Familiarize operators and people responsible for hoist installation and service with ASME B30.16 specifications prior to placing the unit into service. All the requirements of this specification, including testing should be met before approving the hoist for operation.

## Hoist Operation

When facing the hand chain side of the hoist:

- Rotate hand chain clockwise to raise load.
- Rotate hand chain counterclockwise to lower load.

### NOTICE

- **The clicking sound of the pawl on the ratchet gear is normal when a load is being raised.**

## Storing the Hoist

1. Always store the hoist in a no load condition.
2. Wipe off all dirt and water.
3. Oil the chain, hook pins and hook latch pins.
4. Hang in a dry place.
5. Before returning hoist to service follow instructions for Hoists not in Regular Service in the “INSPECTION” section.

## INSPECTION

### ⚠ WARNING

- **All new, altered or modified equipment should be inspected and tested by personnel trained in safety, operation and maintenance of this equipment to ensure safe operation at rated specifications before placing equipment in service.**

Frequent and periodic inspections should be performed on equipment in regular service. Frequent inspections are visual examinations performed by operators or service personnel and include observations made during routine equipment operation. Periodic inspections are thorough inspections conducted by personnel trained in the safety, operation and maintenance of this equipment. ASME B30.16 states inspection intervals depend upon the nature of the critical components of the equipment and the severity of usage.

Careful inspection on a regular basis will reveal potentially dangerous conditions while still in the early stages, allowing corrective action to be taken before the condition becomes dangerous.

Deficiencies revealed through inspection, or noted during operation, must be reported to designated personnel trained in safety, operation and maintenance of this equipment. A determination as to whether a condition constitutes a safety hazard must be decided, and the correction of noted safety hazards accomplished and documented by written report before placing the equipment in service.

## Records and Reports

Inspection records, listing all points requiring periodic inspection should be maintained for all load bearing equipment. Written reports, based on severity of service, should be made on the condition of critical parts as a method of documenting **periodic** inspections. These reports should be dated, signed by the person who performed the inspection, and kept on file where they are readily available for review.

### NOTICE

- **The external placement of coded marks on equipment identifying completed inspections and operationally certified equipment is an acceptable method of documenting periodic inspections in place of written records.**

### Load Chain Reports

Records should be maintained documenting the condition of load chain removed from service as part of a long-range load chain inspection program. Accurate records will establish a relationship between visual observations noted during frequent inspections and the actual condition of the load chain as determined by periodic inspection methods.

### Frequent Inspection

The Manual Chain Hoist should be inspected at the beginning of each shift. Visual inspections should also be conducted during regular service for any damage or evidence of malfunction which appears between regular inspections.

1. **OPERATION.** Check for visual signs or abnormal noises which could indicate a potential problem. Do not operate a hoist unless the chain feeds through the hoist and hook block smoothly. Listen for “clicking”, binding or malfunctioning. The clicking sound of the pawl on the ratchet gear is normal when a load is being raised. If chain binds, jumps, or is excessively noisy, clean and lubricate the chain. If problem persists, replace the chain. Do not operate the hoist until all problems have been corrected. Check that hand chain moves freely and without binding or excessive drag. Hook should stop moving when hand chain stops moving.
2. **HOOKS.** Check for wear or damage, increased throat width, bent shank or twisting of hook. Replace hooks which exceed the throat opening discard width (15%) shown in Table 2 (refer to Dwg. MHP0040) or exceed a 10° twist (refer to Dwg. MHP0111). If the hook latch snaps past the tip of the hook, the hook is sprung and must be replaced. Check hook support bearings for lubrication and damage. Make sure that they swivel easily and smoothly. Repair or lubricate as necessary.

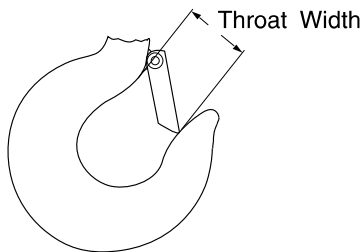

(Dwg. MHP0040)

Table 2

Model No.	Throat Width		Discard Width	
	in.	mm	in.	mm
MCH5-005	1.22	31	1.40	35.6
MCH5-010	1.33	34	1.54	39.1
MCH5-015	1.50	38	1.72	43.7
MCH5-020	1.61	41	1.86	47.2
MCH5-030	1.85	47	2.12	54.0
MCH5-050	2.01	51	2.31	58.6

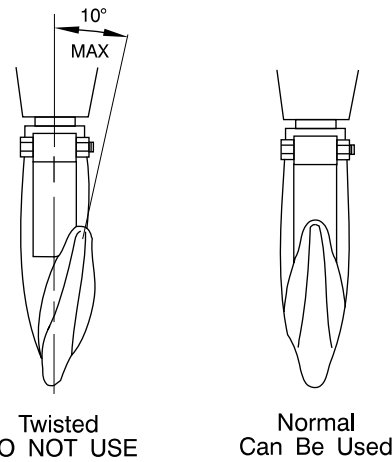

(Dwg. MHP0111)

3. **HOOK LATCHES.** Check operation of the hook latches. Replace if broken or missing.
4. **CHAIN.** Refer to Dwg. MHP0102. Examine each of the links for bending, cracks in weld areas or shoulders, transverse nicks and gouges, weld splatter, corrosion pits, striation (minute parallel lines) and chain wear, including bearing surfaces between chain links. Replace a chain that fails any of the inspections. Check lubrication and lubricate if necessary. Refer to “Load Chain” under “LUBRICATION.”

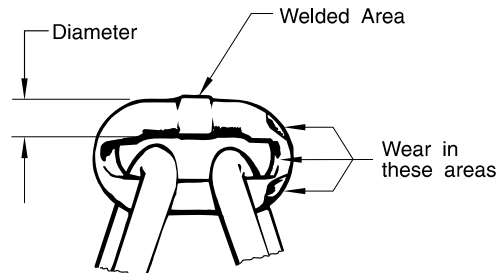

(Dwg. MHP0102)

### CAUTION

• The full extent of chain wear cannot be determined by visual inspection. At any indication of chain wear inspect chain and load sheave in accordance with instructions in “Periodic Inspection.”

5. **LOAD CHAIN REEVING.** Make sure welds on standing links are away from load sheave. Reinstall chain if necessary. Make sure chain is not capsized, twisted or kinked. Adjust as required.

### Periodic Inspection

According to ASME B30.16, frequency of periodic inspection depends on the severity of usage:

<b>NORMAL</b>	<b>HEAVY</b>	<b>SEVERE</b>
yearly	semiannually	quarterly

Disassembly may be required for HEAVY or SEVERE usage. Keep accumulative written records of periodic inspections to provide a basis for continuing evaluation. Inspect all items in “Frequent Inspection.” Also inspect the following:

1. **FASTENERS.** Check rivets, capscrews, nuts, cotter pins and other fasteners on hooks and hoist body. Replace if missing and tighten or secure if loose.

2. ALL COMPONENTS. Inspect for wear, damage, distortion, deformation and cleanliness. If external evidence indicates the need, disassemble. Check gears, shafts, bearings, sheaves, chain guides, springs and covers. Replace worn or damaged parts. Clean, lubricate and reassemble.
3. HOOKS. Inspect hooks for cracks. Use magnetic particle or dye penetrant to check for cracks. Inspect hook retaining parts. Tighten, repair or replace if necessary. Refer to the latest edition of ASME B30.10 (Hooks) for additional hook inspection information.
4. CHAIN SHEAVES. Check for damage or excessive wear. Replace damaged parts.
5. BRAKE. Ensure proper operation. Brake should not slip with test load ( rated capacity). If load test indicates the need, disassemble. Brake discs must be free of excess oil, any grease, unglazed, uniform in thickness and at least 5/64 in. (2 mm) thick. Check all other brake surfaces for wear, deformation or foreign deposits. Inspect pawl brake. Teeth of ratchet gear should be undamaged, and should stop gear rotation in the counterclockwise direction. Check pawl spring for damage. Clean and replace components as necessary.
6. SUPPORTING STRUCTURE. If a permanent structure is used inspect for continued ability to support load.
7. LABELS AND TAGS. Check for presence and legibility. Replace if necessary.
8. END ANCHOR. Ensure end anchor on chain hoist is engaged and unbent. Repair if damaged, replace if missing. Refer to “Attaching End of Load Chain” in “MAINTENANCE” section.
9. LOAD CHAIN. Measure the chain for stretching by measuring across five link sections all along the chain (refer to Dwg. MHP0041). When any five links in the working length reach or exceed the discard length shown in Table 3, replace the entire chain. Always use a genuine **Ingersoll-Rand** Material Handling replacement chain.

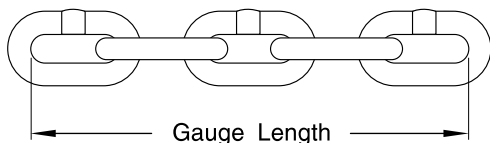

(Dwg. MHP0041)

**Table 3**

Model No.	Part No.	Chain Size	Normal Length		Discard Length	
		mm	in.	mm	in.	mm
MCH5-005	LCCF005	5.0	2.95	75.0	3.03	77.0
MCH5-010	LCCF010	6.3	3.76	95.5	3.85	97.9
MCH5-015	LCCF015	7.1	4.17	106.0	4.28	108.7
MCH5-020	LCCV020	8.0	4.72	120.0	4.84	123.0
MCH5-030	LCCF015	7.1	4.17	106.0	4.28	108.7
MCH5-050	LCCF025	9.0	5.35	136.0	5.47	139.0

## NOTICE

- Zinc plated chain for the MCH5 is designated by “ZP” at the end of the part number.

### Hoists not in Regular Service

1. A hoist that has been idle for a period of one month or more, but less than one year should be given an inspection conforming with the requirements of “Frequent Inspection” before being placed in service.
2. A hoist that has been idle for a period of more than one year should be given a complete inspection conforming with the requirements of “Periodic Inspection” before being placed in service.
3. Standby hoists should be inspected at least semiannually in accordance with the requirements of “Frequent Inspection”. In abnormal operating conditions equipment should be inspected at shorter intervals.

## LUBRICATION

### General

Thread lubricant or an antiseize compound use is recommended for threaded shafts, capscrews and nuts. Unless otherwise stated, remove old lubricant, clean the part with an acid free solvent and apply a new coating of lubricant to the part before assembly.

### Gears (11 and 14)

Unscrew U-nuts (36), on the opposite side of the hoist as the hand chain, and remove gear cover (17) and support plate (16). Remove old grease and replace with new. For temperatures -20° to 50° F (-29° to 10° C) use EP 1 grease or equivalent. For temperatures 30° to 120° F (-1° to 49° C) use EP 2 grease or equivalent.

### Load Chain

## ⚠ WARNING

- Failure to maintain clean and well lubricated load chain may result in chain failure causing injury, death or substantial property damage.

1. Lubricate load chain weekly, or more frequently, depending on severity of service.
2. In a corrosive environment, lubricate more frequently than normal.
3. Lubricate each link of the chain and apply new lubricant over existing layer.
4. Lubricate hook and hook latch pivot points.
5. Clean chain with acid free solvent to remove rust or abrasive dust build-up and lubricate the chain.
6. Use **Ingersoll-Rand** LUBRI-LINK-GREEN or a SAE 50 to 90 EP oil.

## TROUBLESHOOTING

This section provides basic troubleshooting information. Specific causes to problems are best identified by thorough inspections performed by personnel instructed in safety, operation and maintenance of this equipment. The chart below provides a brief guide to common hoist symptoms, probable causes and remedies.

SYMPTOM	CAUSE	REMEDY
Hoist will not lift load.	Hoist is overloaded.	Reduce load to within hoist rated capacity.
Hoist will not hold load.	Brake may be slipping.	Inspect brake. Replace brake discs or repair brake as described in the "MAINTENANCE" section.
	Hoist is overloaded.	Reduce load to within hoist rated capacity.
Load Chain Binds.	Damaged load chain, pinion shaft, gears or sheaves.	Disassemble hoist, inspect and repair or replace damaged components.
	Load chain not installed properly (twisted, kinked or "capsized").	Remove load chain and re-install.
Hand Chain Binds.	Damaged hand chain, hand chain wheel, pinion shaft, gears, load chain, sheaves.	Disassemble hoist, inspect and repair or replace damaged components.
	Hand chain not installed properly (twisted or kinked).	Remove load chain and re-install.
Load Hook Latch does not work.	Latch broken.	Replace hook latch.
	Load hook bent or twisted.	Inspect load hook as described in "INSPECTION" section. Replace if necessary.

## MAINTENANCE

### ⚠ WARNING

- Never perform maintenance on the hoist while it is supporting a load.
- Before performing maintenance, tag hoist:  
**DANGER - DO NOT OPERATE - EQUIPMENT BEING REPAIRED.**
- Only allow personnel trained in operating and servicing this product to perform maintenance.
- After performing maintenance on the hoist, test unit to 125% of its rated capacity before returning to service. Testing to 150% of rated capacity might be required to comply with standards and regulations set forth in areas outside of the USA.

#### Installing New Load Chain

### NOTICE

- Do not remove the old load chain from the hoist. The old load chain can be used to install the new load chain.

### ⚠ WARNING

- To prevent a falling load which can cause death, injury or property damage the hook (38) must be on left fall of load chain (43) and right fall must be attached to hoist body with end anchor (21 and 22). Right and left are designated when viewed from the hand chain side of the hoist.

1. Remove end of load chain from end anchor (21 and 22).
  - a. 1/2, 1, 1-1/2 and 2 ton units are single fall hoists. The load end of the load chain (43) is anchored to the bottom hook assembly (38). To disconnect the load chain from the bottom hook assembly (38) remove chain bolt (39) and U-nut (40).
  - b. 3 and 5 ton units are double chain fall hoists. The load end of the load chain (43) is anchored to the top hook assembly (37). To disconnect the load chain from the top hook assembly (37) remove chain bolt (39) and U-nut (40).
2. Make a "C" link in new load chain by grinding through one side of the end link (refer to Dwg. MHP0016). To avoid twisting, the load chain on 3 and 5 ton units must have an odd number of links, not counting the "C" link.
3. Using a "C" link, join the old load chain to the new load chain. (If the old load chain was installed correctly, the "C" link assures end link of new load chain will be correctly reeved through the hoist.) Be sure welds of "standing" links on the new load chain are facing away from the hoist load sheave(s) (6). Refer to Dwg. MHP0042.

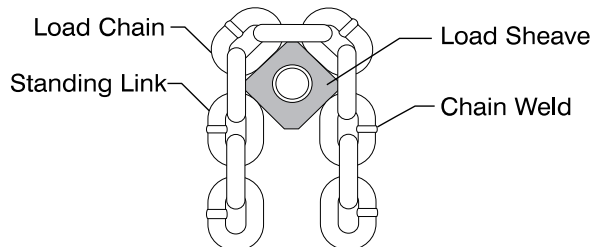

(Dwg. MHP0042)



4. Run the new chain to its anchor point. On smaller units, use the hand chain (42) to move the load chain. On larger units, load chain (43) installation can be speeded up by unscrewing U-nuts (36), removing gear cover (17), support plate (16) and taking out 2nd gear set (14). With the 2nd gear set (14) removed, the load chain (43) can be pulled by hand through the hoist body and hook blocks. Reinstall 2nd gear set, support plate (16), gear cover (17) and U-nuts (36).
5. Remove "C" link and old chain.
6. On 1/2 to 2 ton hoists, anchor load chain (47) to bottom hook block. On 3 and 5 ton units, anchor load chain to top hook frame. To connect, install chain bolt (39) and U-nut (40).

For information on connecting unloaded end of load chain refer to "Attaching End of Load Chain" section.

7. Check for the following:
  - a. The load chain did not become twisted, when reeving the load chain (43) between the idler sheave on the bottom hook assembly and the hoist load sheave. Refer to Dwg. MHP0020.
  - b. Make sure load chain (43) is reeved between load sheave (6) and chain guides (7).

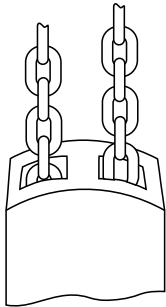

Appearance of chain that is Not Twisted

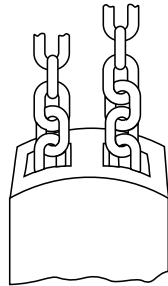

Appearance of chain that Is Twisted

(Dwg. MHP0020)

#### Capsized Hook

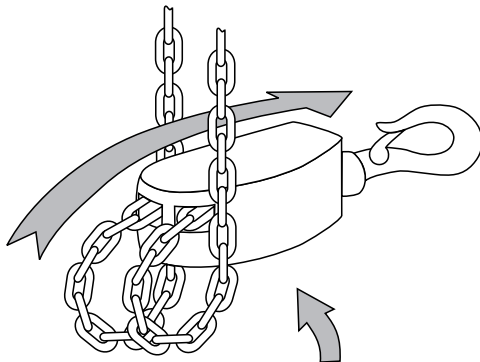

Make certain the bottom block has NOT been flipped through the chain falls

(Dwg. MHP0043)

### Attaching End of Load Chain

Refer to Dwg. MHP0410

1. Push end pin (20) "in", towards end spring (19) and remove end anchor A (21).
2. Slide end link of load chain (43) on end anchor A (21) shaft.
3. Insert end anchor A (21) shaft into end anchor B (22) guide hole.
4. Reinstall end anchor A (21) on end pin (20). Depress and align end pin (20) in side plate 1 (1) hole. When released end pin (20) should spring into position and slide into hole in side plate 1 (1).

Ensure load chain (43) is not twisted, kinked or "capsized." Refer to Dwg. MHP0043.

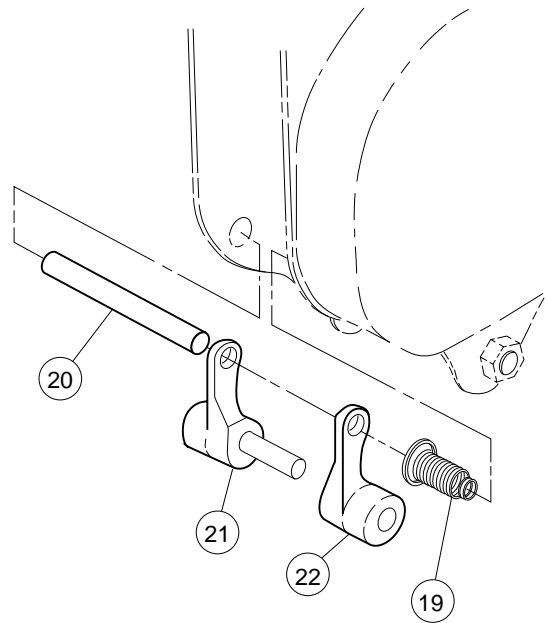

(Dwg. MHP0410)

### Brake Adjustment

1. Unscrew nuts (36) and remove wheel cover (35) so that handwheel (31) is exposed.
2. Remove cotter pin (34) and tighten pinion nut (33) (Clockwise). Hold load chain (47), if necessary, to keep pinion shaft (13) from rotating.
3. Back off pinion nut (33) approximately 1/8th of a turn (Counterclockwise) and reinsert cotter pin (34).
4. Remove all slack from the chain.
5. Pull on the hand chain to lift the load approximately 2 feet (0.5 m) off the floor.

### General Disassembly

The following instructions provide the necessary information to disassemble, inspect, repair, and assemble the hoist. Parts drawings of the hoist assembly are provided in the Parts Section. If a hoist is being completely disassembled for any reason, follow the order of the topics as they are presented. It is recommended that all maintenance work on the hoist be performed on a bench.

In the process of disassembling the hoist, observe the following:

1. Never disassemble the hoist any further than is necessary to accomplish the needed repair. A good part can be damaged during the course of disassembly.
2. Never use excessive force when removing parts. Tapping gently around the perimeter of a cover or housing with a soft hammer, for example, is sufficient to break the seal.

- Do not heat a part with a flame to free it for removal unless the part being heated is already worn or damaged beyond repair and no additional damage will occur to other parts. In general, the hoist is designed to permit easy disassembly and assembly. The use of heat or excessive force should not be required.
- Keep the work area as clean as practical, to prevent dirt and other foreign matter from getting into bearings or other moving parts.
- When grasping a part in a vise, always use leather-covered or copper-covered vise jaws to protect the surface of the part and help prevent distortion. This is particularly true of threaded members, machined surfaces and housings.
- Do not remove any part which is press fit in or on a subassembly unless the removal of that part is necessary for repairs or replacement.

## Disassembly

### Brake Disc Replacement

- Unscrew U-nuts (36). Remove wheel cover (35).
- Remove hand chain (46) from hand wheel (31).
- Remove cotter pin (34), unscrew pinion nut (33) and remove washer (32).
- Remove hand wheel (31) by holding the load chain (43) and rotating hand wheel (31) counterclockwise until it can be lifted off pinion shaft (13).
- Remove brake cover (30) and brake disc A (27).
- Remove ratchet gear (29) and brake disc B (28).

## Cleaning, Inspection and Repair

Use the following procedures to clean and inspect the components of the hoist.

### Cleaning

Clean all hoist component parts in an acid free solvent (except for the brake disc). The use of a stiff bristle brush will facilitate the removal of accumulated dirt and sediments on the gears and frames. Dry each part using low pressure, filtered compressed air.

### Inspection

All disassembled parts should be inspected to determine their fitness for continued use. Pay particular attention to the following:

- Inspect all gears for worn, cracked, or broken teeth.
- Inspect shafts for ridges caused by wear. If ridges caused by wear are apparent on shafts, replace the shaft.
- Inspect all threaded items and replace those having damaged threads.
- Measure the thickness of the brake discs. If brake discs do not have uniform thickness or are less than 5/64 in. (2 mm) thick replace brake discs.

### Repair

Actual repairs are limited to the removal of small burrs and other minor surface imperfections from gears and shafts. Use a fine stone or emery cloth for this work.

- Worn or damaged parts must be replaced. Refer to the applicable parts listing for specific replacement parts information.
- Inspect all remaining parts for evidence of damage. Replace or repair any part which is in questionable condition. The cost of the part is often minor in comparison with the cost of redoing the job.
- Smooth out all nicks, burrs, or galled spots on shafts, bores, pins, and bushings.
- Examine all gear teeth carefully, and remove nicks and burrs.

- Polish the edges of all shaft shoulders to remove small nicks which may have been caused during handling.
- Remove all nicks and burrs caused by lockwashers.

## Assembly



• **The brake will not operate properly if there is too much oil on the brake discs (27 and 28). Excessive oil or grease on brake components could cause the load to slip.**

- Dip replacement brake discs (27 and 28) in ISO VG32 hydraulic oil or SAE 10 oil for two seconds. Wipe off excess oil.
- Place brake disc B (28) over hub (26). Brake disc B (28) has a smaller outside diameter than brake disc A (27).
- Install ratchet gear (29) on hub (26) so recessed face fits over brake disc B. Teeth of ratchet gear (29) must engage pawl (24). Ratchet gear (29) should not rotate counterclockwise and should “click” when rotating clockwise.
- Place brake disc A (27) on ratchet gear (29).
- Place brake cover (30) over stay bolts on side plate 1 assembly (1).
- With brake surface of handwheel (31) towards the brake disc A (27), place handwheel (31) on pinion shaft (13). Rotate handwheel (31) clockwise until clicking occurs. Hold load chain (43) if necessary.
- Place washer (32) over pinion (13). Install pinion nut (33) and cotter pin (34). Refer to “Brake Adjustment.”
- Install hand chain (42) on handwheel (31). Make sure hand chain (42) is seated properly.
- Place wheel cover (35) over stay bolts. Install U-nuts (36).

## Gears (14)

1/2, 1 and 2 ton units do not use gears with a circle.

On 1-1/2, 3 and 5 ton units, each hoist body must have one gear without a “circle” and one gear with a “circle”. Refer to Dwg. MHP0044.

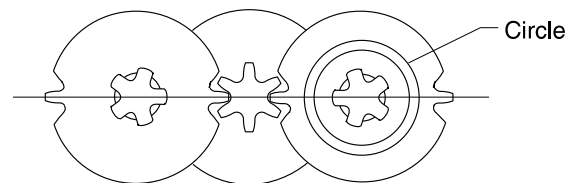

(Dwg. MHP0044)

## NOTICE

• **The 1/2 ton hoist has a center pinion gear with only 5 teeth.**

## Hand Chain Adjustment or Replacement

### CAUTION

• When cutting the weld side of a hand chain link, do not cut or nick the opposite side. A damaged link must be replaced to prevent premature failure. A falling hand chain could cause injury.

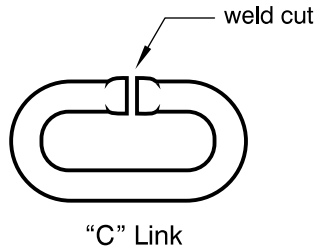

(Dwg. MHP0016)

1. To create a "C" link, cut the welded side of the link with a hack saw. Clamp one side of the "C" link in a vise and bend it open by using a pliers to grip the exposed part of the link.

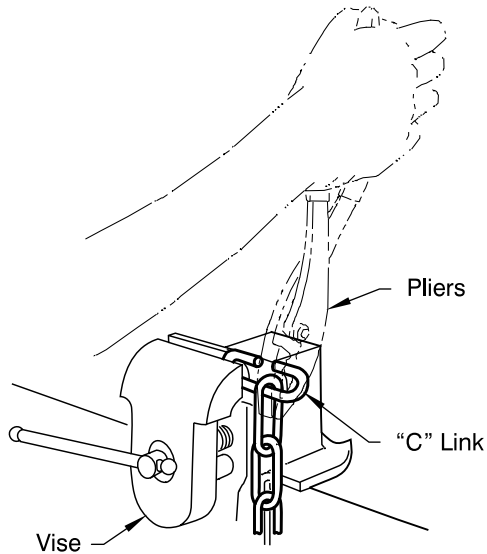

(Dwg. MHP0014)

2. If you are replacing the hand chain, disconnect it at the "C" link and carefully remove the hand chain.
3. When replacing a hand chain, cut a length 2 times the required hand chain drop plus about one foot (305 mm). For adjustments, remove or add a length of chain twice the difference in hand chain height. To prevent the hand chain from twisting, maintain an even number of links, by removing or adding an even number of links.
4. If you are replacing the hand chain, run the new hand chain up through the left hand chain guide, around the handwheel, making sure the hand chain is seated in the handwheel pockets, and back down through the right hand chain guide.
5. Connect the hand chain ends with the "C" link(s), making the total number of links even, and bend the "C" link(s) shut.
6. Make sure the hand chain is not twisted. If twisted, untwist or open a "C" link and remove one hand chain link if necessary.

### Load Test

Prior to initial use, all new, extensively repaired, or altered hoists shall be load tested by or under the direction of a person trained in the operation and maintenance of this hoist, and a written report furnished confirming the rating of the hoist. Test hoist to 125% of its rated capacity. Testing to more than 125% may be necessary to comply with standards and regulations set forth in areas outside of the USA.

# HOIST ASSEMBLY PARTS DRAWING

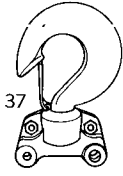

**3ton, 5ton Top Hook Set**

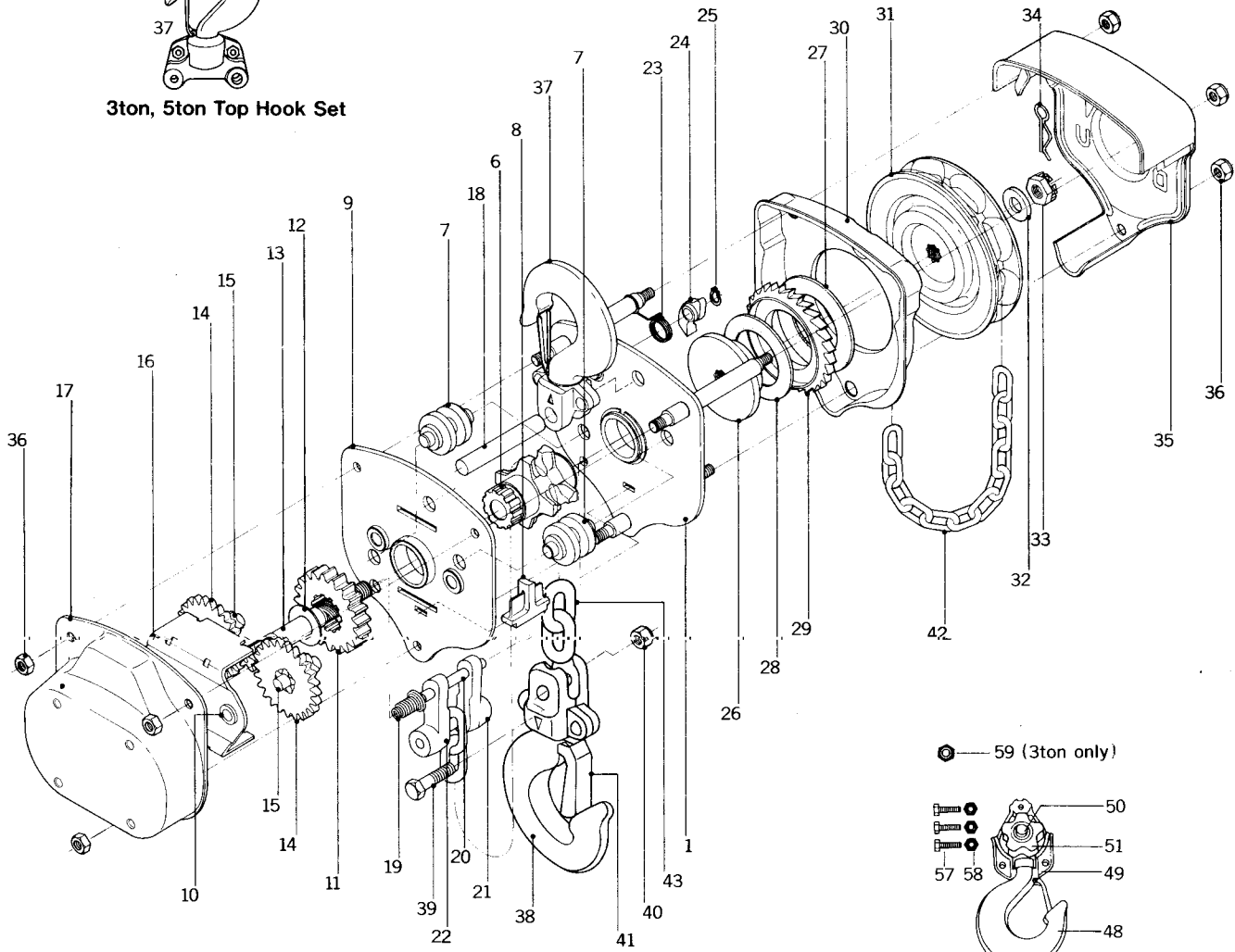

● 59 (3ton only)

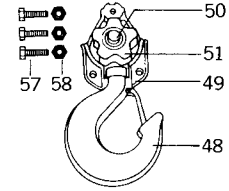

**3ton, 5ton Bottom Hook Set**

(Dwg. MHP0439)

## HOIST ASSEMBLY PARTS LIST

ITEM NO.	DESCRIPTION OF PART	QTY. TOTAL	PART NO.					
			1/2 ton	1 ton	1-1/2 ton	2 ton	3 ton	5 ton
1	Side Plate 1 Assy. (Incl's item 5)	1	2373182	2373183	2373184	2373185	2373184	2373186
6	Load Sheave	1	2372784	2372826	2372852	2372871	2372852	2372905
7	Load Chain Guide	2	2372785	2372827		2372872	2372827	2372872
8	Chain Stripper	1	2372786	2372828		2372873	2372828	2372873
9	Side Plate 2 Assembly	1	71046544	71046551	71046569	71046577	71046569	71046585
10	Gear Bushing	4	2372788			2372875	2372788	2372875
11	1st Gear	1	2372789	2372830	2372854	2372876	2372854	2372907
12	Pinion Washer	1	2372790	---				
13	Pinion Shaft	1	2372791	2372831		2372877	2372831	2372877
14	2nd Gear Set (Plain/Plain)	1(2) Set(s)	2372792	2372832	71050736	2372878	71050736	71050751
	2nd Gear Set (Plain/Circle)	1(2) Set(s)	---		71050744	---	71050744	71050769
15	3rd Gear	2	2372793	2372833		2372879	2372833	2372909
16	Support Plate	1	2372794	2372834	2372856	2372880	2372856	2372910
17	Gear Cover	1	2372795	2372835	2372857	2372881	2372857	2372911
18	Hook Pin	1	2372796	2372836		2372882	2372836	2372912
19	End Spring	1	2372797					
20	End Pin	1	2372798	2372837		2372883	2372837	2372883
21	End Anchor A	1	2372799	2372838		2372884	2372838	2372884
22	End Anchor B	1	2372800	2372839		2372885	2372839	2372885
23	Spring	1	2372801	2372840	2372858	2372886	2372858	2372913
24	Pawl	1	2372802			2372887	2372802	2372887
25	Snap Link	1	2372803			2372888	2372803	2372888
26	Hub	1	2372804	2372841		2372889	2372841	2372889
• 27	Brake Disc "A"	1 set	71112353			71112361	71112353	71112361
• 28	Brake Disc "B"							
29	Ratchet Gear	1	2372807			2372891	2372807	2372891
30	Brake Cover	1	2372808	2372842	2372859	2372892	2372859	2372914
31	Handwheel	1	2372809	2372843	2372860	2372893	2372860	2372915
32	Washer	1	2372810					
33	Pinion Nut	1	2372811					
34	Cotter Pin	1	2372812					
35	Wheel Cover	1	2372813	2372844	2372861	2372894	2372861	2372916
36	U-Nut	6	2372814			2372895	2372814	2372895
37	Top Hook Set	1	2372815	2372845	2372862	2372896	2372922	2372938
• 38	Bottom Hook Set	1	2373187	2373188	2373189	2373190	2373191	2373192
• 39	Chain Bolt	1	2372818	2372848		2372899	2372848	2372920
• 40	U-Nut	1	2372819	2372849		2372900	2372849	2372900
• 41	Hook Latch Kit	2	2372820	2372850	2372865	2372901	2372925	2372941
42	Hand Chain	As Req'd	HCCB005			HCCV020	HCCB005	HCCV020
	Hand Chain (Zinc Plated)**		HCCB005ZP			HCCV020ZP	HCCB005ZP	HCCV020ZP
43	Load Chain	As Req'd	LCCF005	LCCF010	LCCF015	LCCV020	LCCF015	LCCF025
	Load Chain (Zinc Plated)**		LCCF005ZP	LCCF010ZP	LCCF015ZP	LCCV020ZP	LCCF015ZP	LCCF025ZP
	Load Chain (Nickel Diffused)		LCCF005ND	LCCF010ND	LCCF015ND	LCCV020ND	LCCF015ND	LCCF025ND
• 48	Bottom Hook (only)	1	---				2373193	2373194
49	Bottom Frame (only)	2	---				2372930	2372946
50	Axle	1	---				2372931	2372947
51	Sheave with Bushing	1	---				2373195	2372948
57	Yoke Bolt	3	---				2372783	2372825
58	Yoke Nut	3	---				2372816	2372846
59	Axle Nut	1	---				2372918	---
60*	Warning Label	1	71038863					
61*	Model Label	1	71087191	71087209	71087217	71087225	71087233	71087241
•	Recommended Spare		* Not shown on drawing			** European hoist version only		

## ACCESSORIES

Description	Part No.
Orange Touch-Up Paint	MHD-OR
Chain Lubricant	LUBRI-LINK-GREEN

## PARTS ORDERING INFORMATION

The use of other than genuine **Ingersoll-Rand** Material Handling replacement parts may adversely affect the safe operation of this product.

When ordering replacement parts, please specify the following:

1. Complete model number as it appears on the nameplate:  
**MCH5** plus capacity.
2. Part number and part name as shown in manual.
3. Quantity required.

The hoist model label is located on the gear cover. Example shown is for a 3 ton **MCH5**.



For your convenience and future reference it is recommended that the following information be recorded.

**Hoist Model Number** \_\_\_\_\_

**Hoist Serial Number** \_\_\_\_\_

**Date Purchased** \_\_\_\_\_

### Return Goods Policy

**Ingersoll-Rand** will not accept any returned goods for warranty or service work unless prior arrangements have been made and written authorization has been provided from the location where the goods were purchased.

Hoists returned with opened, bent or twisted hooks, or without chain and hooks, will not be repaired or replaced under warranty.

### NOTICE

- **Continuing improvement and advancement of design may cause changes to this hoist which are not included in this manual. Manuals are periodically revised to incorporate changes. Always check the manual edition number on the front cover for the latest issue.**

- **If your hoist has special finish requirements for painted parts, please specify when ordering.**

### Disposal

When the life of the hoist has expired, it is recommended that the hoist be disassembled, degreased and parts separated as to materials so that they may be recycled.

For additional information contact:

#### **Ingersoll-Rand Distribution Center**

P. O. Box 618  
510 Hester Drive  
White House, TN 37188  
Phone: (615) 672-0321  
Fax: (615) 672-0801

or

#### **Europe, Middle East and Africa**

#### **Ingersoll-Rand Company**

Swan Lane,  
Hindley Green,  
Wigan  
WN2 4EZ  
U. K.  
Phone: (44) 1942 257131  
Fax: (44) 1942 255045

# WARRANTY

## LIMITED WARRANTY

**Ingersoll-Rand Company (I-R)** warrants to the original user its Hoists and Winches (Products) to be free of defects in material and workmanship for a period of one year from the date of purchase. **I-R** will repair, without cost, any Product found to be defective, including parts and labor charges, or at its option, will replace such Products or refund the purchase price less a reasonable allowance for depreciation, in exchange for the Product. Repairs or replacements are warranted for the remainder of the original warranty period.

If any Product proves defective within its original one year warranty period, it should be returned to any Authorized Hoist and Winch Service Distributor, transportation prepaid with proof of purchase or warranty card.

This warranty does not apply to Products which **I-R** has determined to have been misused or abused, improperly maintained by the user, or where the malfunction or defect can be attributed to the use of non-genuine **I-R** parts.

**I-R makes no other warranty, and all implied warranties including any warranty of merchantability or fitness for a particular purpose are limited to the duration of the expressed warranty period as set forth above. I-R's maximum liability is limited to the purchase price of the Product and in no event shall I-R be liable for any consequential, indirect, incidental, or special damages of any nature rising from the sale or use of the Product, whether based on contract, tort, or otherwise.**

**Note:** Some states do not allow limitations on incidental or consequential damages or how long an implied warranty lasts so that the above limitations may not apply to you.

This warranty gives you specific legal rights and you may also have other rights which may vary from state to state.

## IMPORTANT NOTICE

It is our policy to promote safe delivery of all orders.

This shipment has been thoroughly checked, packed and inspected before leaving our plant and receipt for it in good condition has been received from the carrier. Any loss or damage which occurs to this shipment while enroute is not due to any action or conduct of the manufacturer.

### VISIBLE LOSS OR DAMAGE

If any of the goods called for on the bill of lading or express receipt are damaged or the quantity is short, do not accept them until the freight or express agent makes an appropriate notation on your freight bill or express receipt.

### CONCEALED LOSS OR DAMAGE

When a shipment has been delivered to you in apparent good condition, but upon opening the crate or container, loss or damage has taken place while in transit, notify the carrier's agent immediately.

### DAMAGE CLAIMS

You must file claims for damage with the carrier. It is the transportation company's responsibility to reimburse you for repair or replacement of goods damaged in shipment. Claims for loss or damage in shipment must not be deducted from the **Ingersoll-Rand** invoice, nor should payment of **Ingersoll-Rand** invoice be withheld awaiting adjustment of such claims as the carrier guarantees safe delivery.

You may return products damaged in shipment to us for repair, which services will be for your account and form your basis for claim against the carrier.

## United States Office Locations

### For Order Entry, Order Status and Technical Support

**Ingersoll-Rand  
Distribution Center**  
P.O. Box 618  
510 Hester Drive  
White House, TN 37188  
Phone: (615) 672-0321  
Fax: (615) 672-0801

### Regional Sales Offices

**Chicago, IL**  
888 Industrial Drive  
Elmhurst, IL 60126  
Phone: (630) 530-3800  
Fax: (630) 530-3891

**Detroit, MI**  
23192 Commerce Drive  
Farmington Hills, MI 48335  
Phone: (810) 476-6677  
Fax: (810) 476-6670

**Houston, TX**  
Suite 150  
2500 East T.C. Jester  
Houston, TX 77008  
Phone: (713) 864-3700  
Fax: (713) 864-2244

**Los Angeles, CA**  
11909 E. Telegraph Road  
Santa Fe Springs, CA 90670  
Phone: (310) 948-4189  
Fax: (310) 948-1828

**Philadelphia, PA**  
P.O. Box 425  
900 E. 8th Ave., Suite 103  
King of Prussia, PA 19406  
Phone: (610) 337-5930  
Fax: (610) 337-5912

## International Office Locations

Offices and distributors in principal cities throughout the world. Contact the nearest **Ingersoll-Rand** office for the name and address of the distributor in your country or write/fax to:

**Ingersoll-Rand  
Distribution Center**  
P.O. Box 618  
510 Hester Drive  
White House, TN 37188  
Phone: (615) 672-0321  
Fax: (615) 672-0801

**Canada  
National Sales Office  
Regional Warehouse  
Toronto, Ontario**  
51 Worcester Road  
Rexdale, Ontario  
M9W 4K2  
Phone: (416) 675-5611  
Fax: (416) 213-4510  
Order Desk  
Fax: (416) 213-4506

### Regional Sales Offices

**Calgary, Alberta**  
44 Harley Road S.E.  
Calgary, Alberta  
T2V 3K3  
Phone: (403) 252-4180  
Fax: (403) 252-4462

**Edmonton, Alberta**  
1430 Weber Center  
5555 Calgary Trail N.W.  
Edmonton, Alberta  
T6H 5G8  
Phone: (403) 438-5039  
Fax: (403) 437-3145

**Montreal, Quebec**  
3501 St. Charles Blvd.  
Kirkland, Quebec  
H9H 4S3  
Phone: (514) 695-9040  
Fax: (514) 695-0963

**British Columbia**  
201-6351 Westminster Hwy  
Richmond, B. C.  
V7C 5C7  
Phone: (604) 278-0459  
Fax: (604) 278-1254

**Latin America Operations  
Ingersoll-Rand  
Production Equipment Group**  
730 N.W. 107 Avenue, Suite 300  
Miami, FL 33172-3107 USA  
Phone: (305) 559-0500  
Fax: (305) 559-7505

**Europe, Middle East and Africa  
Ingersoll-Rand Company**  
Swan Lane,  
Hindley Green,  
Wigan  
WN2 4EZ  
U. K.  
Phone: (44) 1942 257131  
Fax: (44) 1942 255045

**Asia Pacific Operations  
Ingersoll-Rand (Japan) Ltd.**  
Shin-Yokohama Square Bldg.  
(5th Floor)  
2-3-12 Shin-Yokohama,  
Kouhoku-Ku,  
Yokohama-shi, Kanagawa  
Pref. 222 Japan  
Phone: 81-45-476-7800  
Fax: 81-45-476-7806

**Russia  
Ingersoll-Rand Company**  
World Trade Center  
Office 1101  
Krasnopresnenskaya Nab. 12  
Moscow, Russia 123610